



Status per. mid. 2011:  
The plant efficiency is now 72 %  
and it has been in operation for  
approx. 7,000 hrs.

## GASIFICATION OF BIOMASS IS A SUCCESS

Gasification of biomass is not a newly invented technology. As an example, during the Second World War the technology was already being used to produce gas from biomass for car engines because of the strict rationing of petrol. Since then the development of the gasification technology has moved very slowly. Primarily because of the presence of ample amounts of cheap and easily transformed fossil fuel and the competition with other technologies that are less research demanding as for example boiler plants and gas turbines. However climate changes issues and the increase in the cost of fossil fuels have created a new

reality where the gasification technology has a big potential.

**GASIFICATION AT I/S SKIVE DISTRICT HEATING**  
Like many other decentralized CHP plants I/S Skive District Heating had at the turn of the new millennium a need to base their production on a cheaper main fuel than natural gas. At that time promising technical and economical possibilities with thermal gasification of biomass were emerging. And as it was one of the few possibilities allowed by that period's legislation, the board of I/S Skive District Heating decided to establish

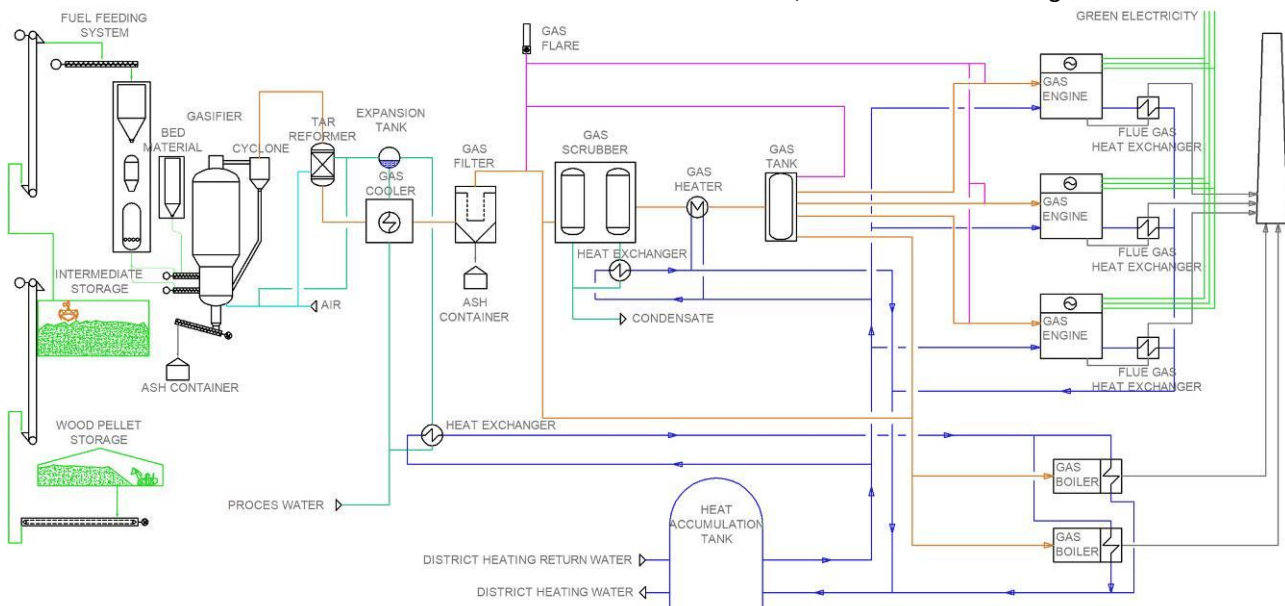



a biomass gasification plant to replace the natural gas CHP production. Since Skive District Heating I/S had already used the expertise of AAEN A/S's employees regarding district heating with good results, AAEN A/S was given the task of completing a feasibility study and preparing a project proposal for the gasification plant.

### THE STORY OF THE PROJECT

With AAEN A/S as client advisor a co-operation with the Finnish company Carbona OY, which had extensive experience in developing plants for thermal gasification of biomass, was commenced. Gasification tests were performed at Carbona's pilot plant in Finland – a so-called fluidized bed gasification plant – utilizing the same wood pellets as used in the boiler plants in Skive. The purpose of the gasification tests was partly to determine the dimensions for a possible gasification plant in Skive, partly to clarify if the catalyst technology developed in Finland could cleanse the gas sufficiently for tar substances to make the gas usable for gas engines.

The gasification tests had positive results and a project proposal was drawn up, which clarified technical questions as well as plant economic issues and socio-economic issues for district heating consumers and I/S Skive District Heating. The project proposal was approved by Skive City Council in 2002 and subsequently the board of I/S Skive District Heating decided to establish the gasification plant on the

company's property on Thorsvej, where the existing biomass boilers are producing district heating from wood pellets.

The economic and technological aspects that weighed the most in the board's decision to establish the plant were the economic support that had been applied for and granted by both the Danish Energy Agency, the EU and the DOE (Department of Energy) in the United States. These commitments of support testified to the mentioned institutions' wish and belief that the gasification technology would become a competitive CO<sub>2</sub>-neutral method of CHP production in the foreseeable future.

Furthermore, it was very important to the permitting authorities and to I/S Skive District Heating that this was a 2<sup>nd</sup> generation technology that has the potential of being developed into a production facility for liquid fuel for transport purposes.

### INITIATION

The actual project was initiated with AAEN A/S as client advisor and the agreement with Carbona was extended to include the project design of the heart of the entire plant, namely the gasifier and all relevant auxiliary equipment. Design of additional plant elements like engines/ generators, SRO-plants for the whole decentralized CHP plant as well as the construction was put into EU Tenders.



Besides the design, tendering and purchase of equipment, delivery and assembly, an extensive Environmental Impact Assessment (EIA) was initiated. The EIA conditions needed to be considered together with an environmental approval from the municipality. In addition an ATEX and a HAZOP analyses were made that needed to be approved by the chief officer of Skive Municipality fire department with the assistance from the Danish Technological Institute.

The EIA case was completed in cooperation with the County of Viborg. The administrative procedures were lengthened because of the novelty of the technology in question, with no previous cases to refer to.

Then the municipal environmental review by Skive Municipality followed. At that time no gasification plant had received environmental approval, meaning that this was a challenging task for Skive Municipality, but in 2005 the plant was given its environmental approval.

### FOLLOW-UP

After the establishment of the plant the great insecurity regarding the environmental aspects, which the long case discussion expressed, has resulted in the need of many modifications and adjustments with a follow-up from Skive Municipality as the environmental authority.

As client advisor, AAEN A/S has been in charge of correspondence with the authorities from the preparation of project proposal to the preparation of the VVM-screening and environment and waste water applications. AAEN A/S has therefore played a central role in I/S Skive District Heating's establishment of the biggest fluidized bed biomass gasification plant in Scandinavia, which in 2009 produced and delivered its first electricity and heat to its respective networks.

